

Two-Piece Adjustable Upper Mast Honeywell DuraHoist™

Product information



The Miller DuraHoist Two-Piece Adjustable Mast system comprised of the DH-23 and DH-22 Series (Lower Mast Extensions), are designed to provide additional solutions when extra operating reach is required. The Two-Piece Mast system allows use of components in various configurations and applications. Multiple winches and/or self retracting lifeline systems may be mounted as required. Tool-less design breaks the system into lightweight, manageable components for storage, transport, and setup.

... [Read more](#)

Material: Welded Aluminum, Zinc Plated, Aluminum, Black Acetal, White UHMW Polyethylene, Stainless Steel

Finish: Safety Yellow Powder Coat

Two-Piece Adjustable Upper Mast Honeywell DuraHoist™

Blueprint

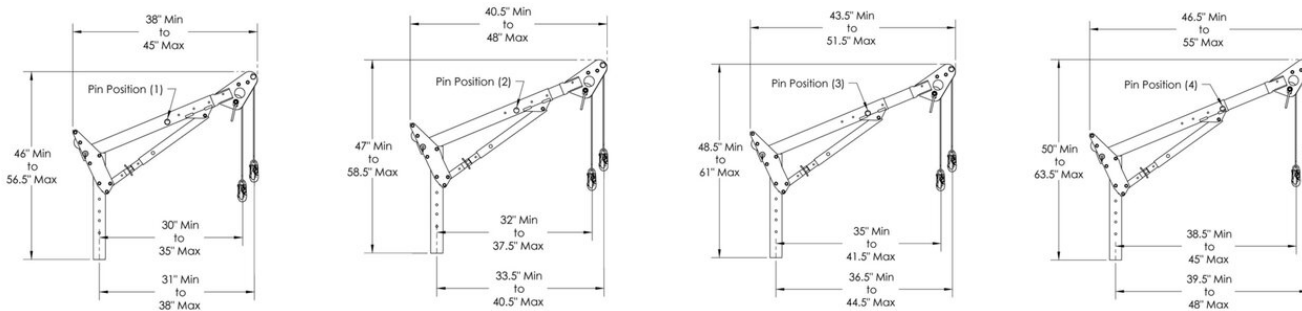

Technical data

Part Code	WLL ton	Weight (kg)
8298DH23	0.204	13.2